

MEIKŪ

CAP TIP DRESSER

Type ETD-18A · ETD-25A

Design Registered/Patent Pending



- ★ **Holding for dressing**
- ★ **One-hand operation possible**
- ★ **Easy tip clamp and tool rotation**

Photo: Type ETD-18A

Specifications

Type	Tip size mm (aprox.)	Clamp open size mm (aprox.)	No-load R.P.M (aprox.)	Air consumption m ³ /min (aprox.)	Air pressure kg/cm ² (aprox.)	Overall length mm (aprox.)	Weight kg (aprox.)	Hose inner dia mm (aprox.)
ETD-18A	9~16	25	1,300	0.5	5~6	309	2.0	9.5
ETD-25A	19~25	25	1,100	0.5	5~6	316	2.03	9.5

Note: The cutter and cutter case are common for type ETD-18A and 18F. ETD-25A is common with 25F.

Set components

- This unit (Set up the clamp plate of the specified size.) ... 1
- Cutter case (Specified size) ... 1

Combination of cutter case and cap tip

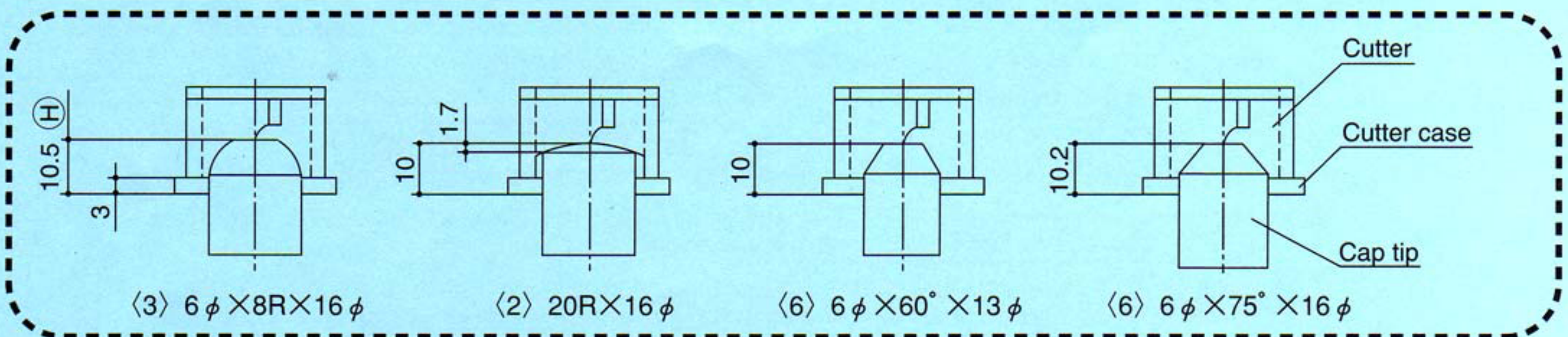

Note: The dimension (H) varies depending on the diameter and shape of the tip.

ex. 6R → 9.3 / 6.5R → 9.5 / 8R → 10.5

Types of Cutter Cases

The cutter case bore diameter ($D\phi$) acts as a guide so that the cutter dresses at the correct location relative to the tip. Please specify a cutter case that matches the tip size.

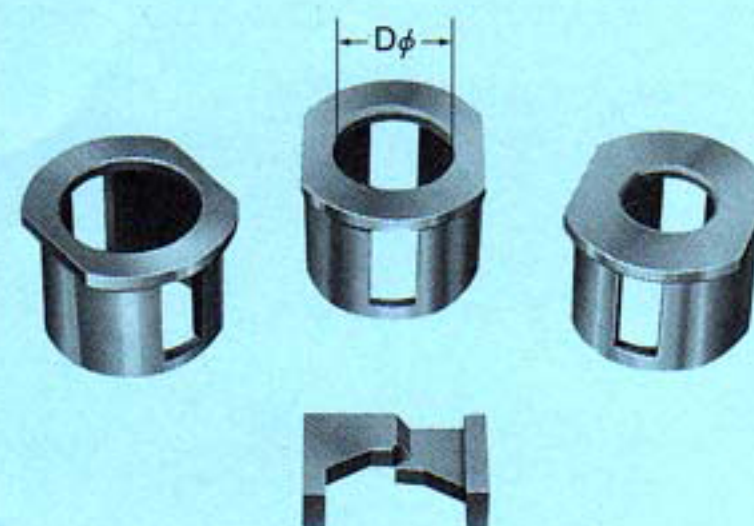

Cutter Cases and Cutter

Cap tip length and correctable dimension

- ex.
- | | | |
|-----------|-------|------|
| 16φ × 25ℓ | | 11mm |
| 16φ × 23ℓ | | 9mm |
| 13φ × 20ℓ | | 6mm |

Standard cap tip dresser

(fig.1)

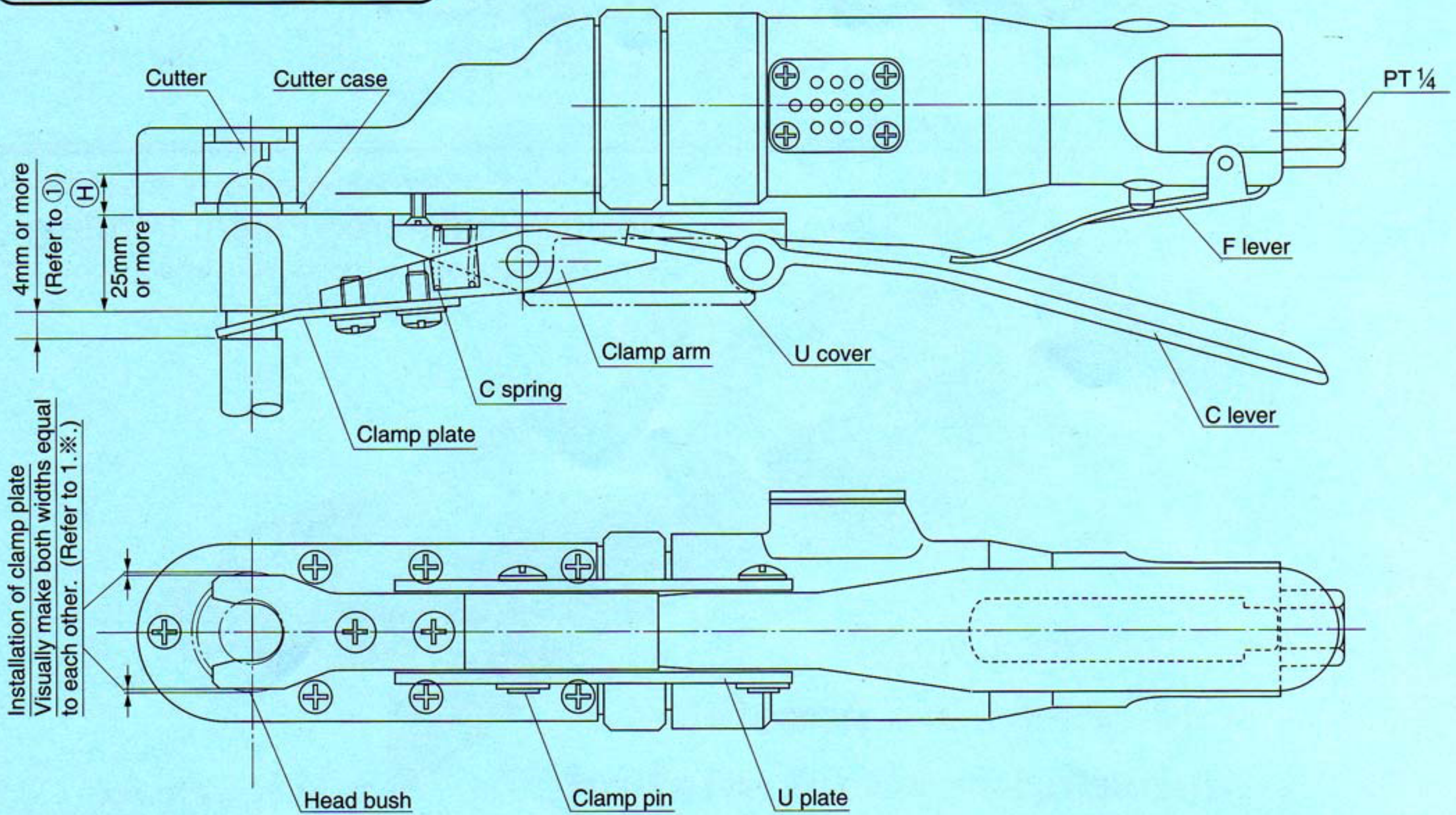

Correction of eccentric tip

Normally for inner eccentricity (shown below) and outer eccentricity types possible

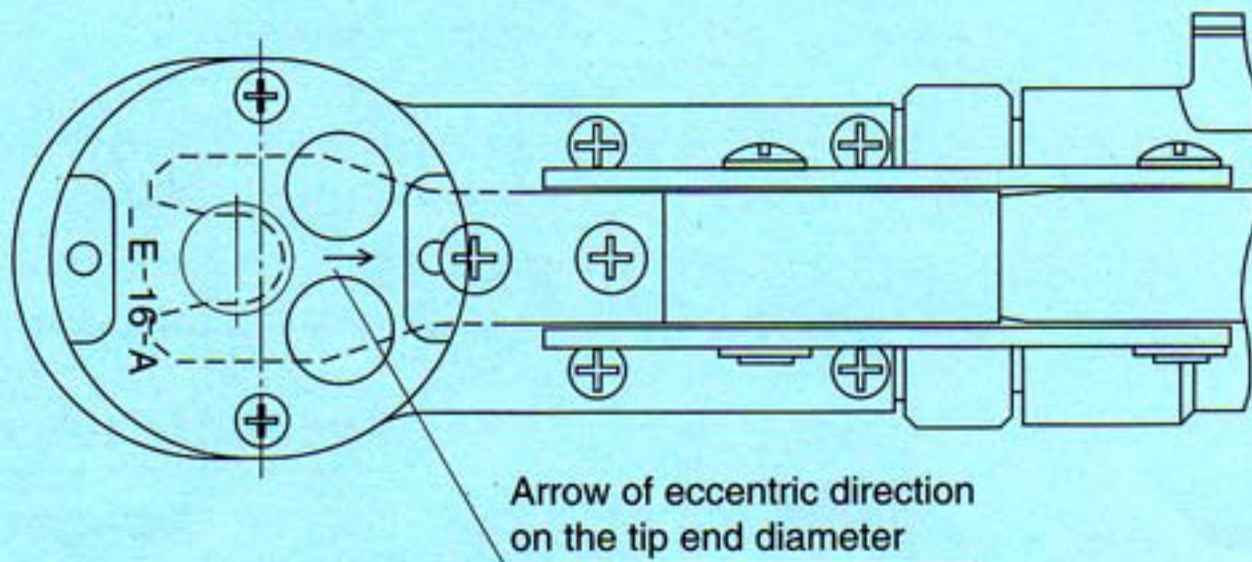
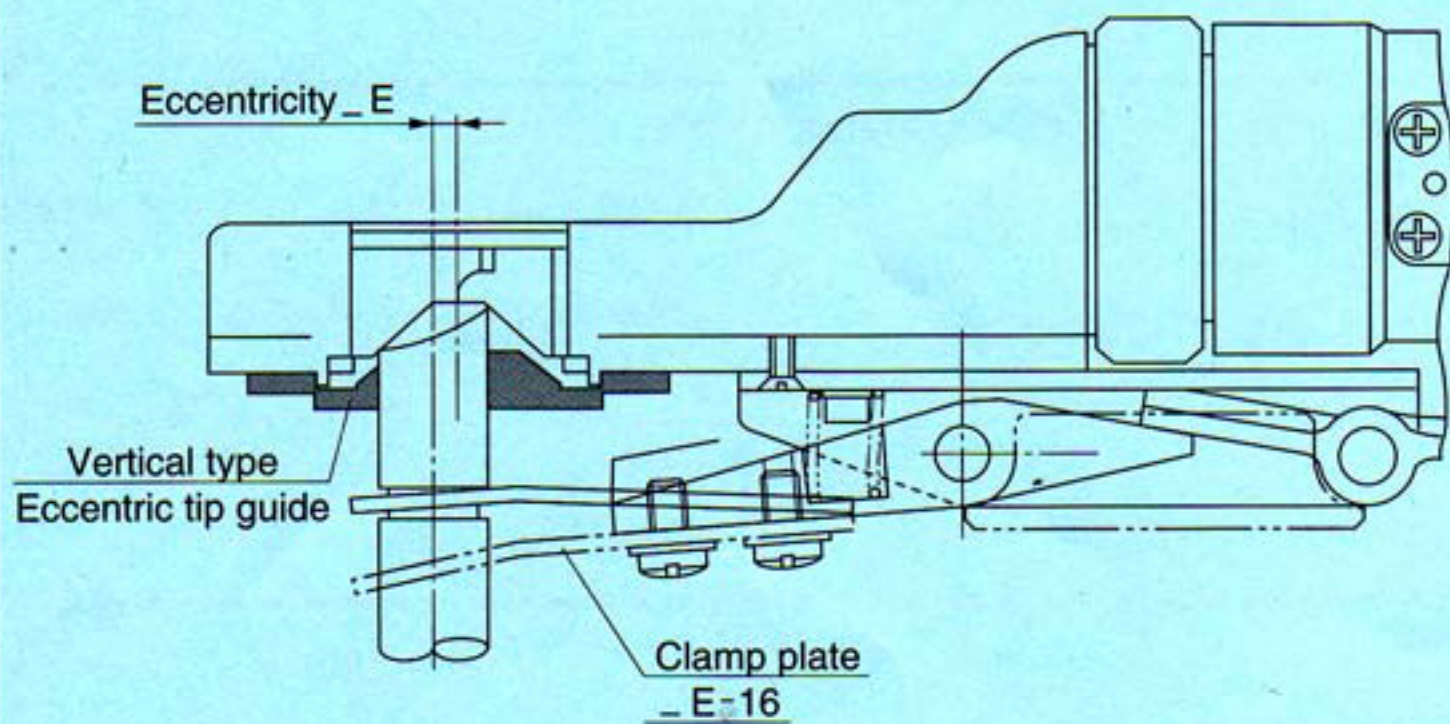

Tool type ETD-25A-E

Installation of fixed tip guide

The tip is stably held for smooth finishing.

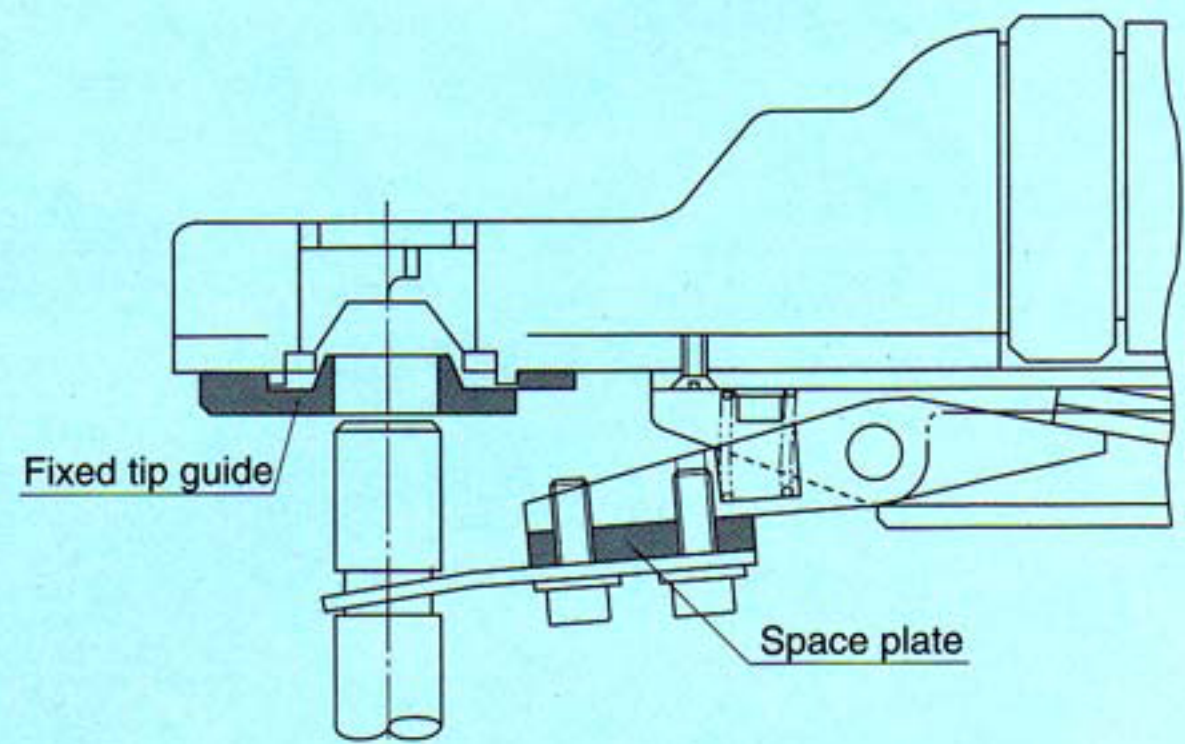

Type ETD-18A (25A) -G

Tip end 15° cutting

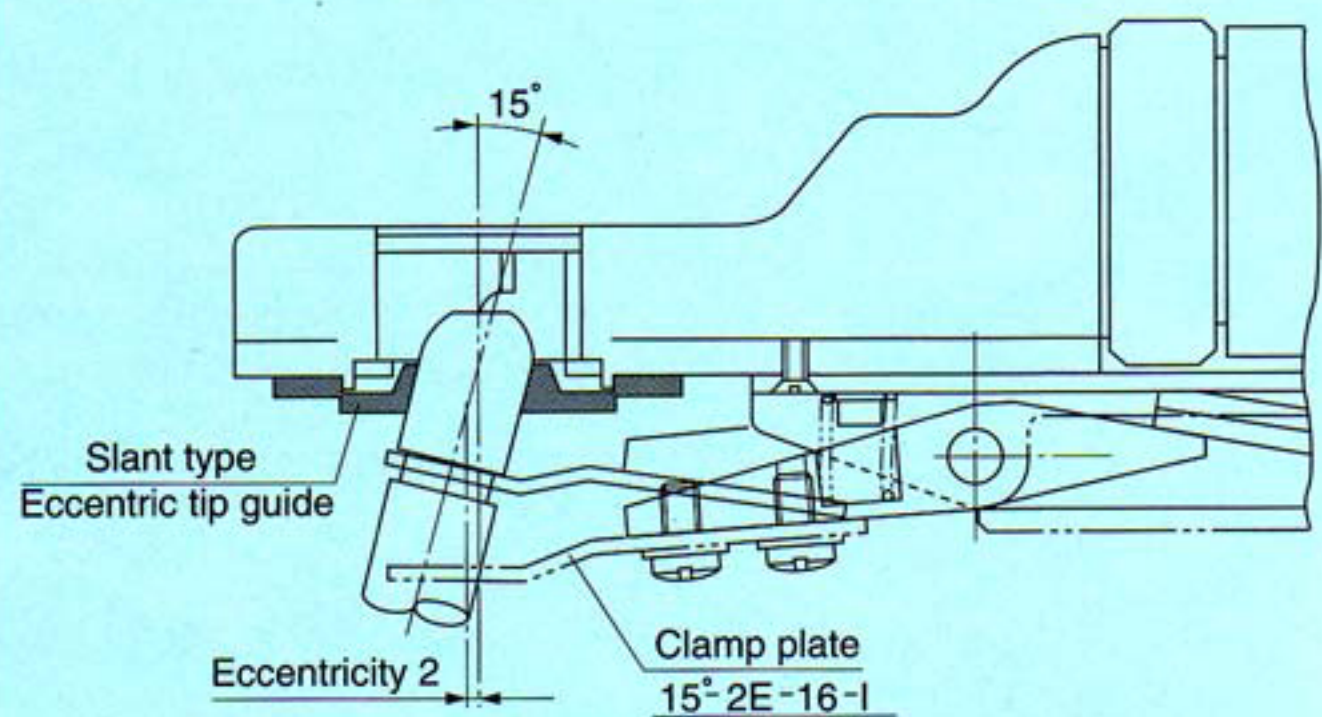

Tool type ETD-25A-E

Moreover, the special tips of various types can be corrected. Please contact MEIKU MANUFACTURING

CAP TIP DRESSER

Tool Handling Instruction

Type ETD-18A · 25A

① The insertion part (width) of clamp plate = The gap must be 4mm or more. (fig.1)

⚠ If it is 4mm or less wide, the clamp plate may not move smoothly or the cap tip may be pried off by the clamp chip. (Cooling water will spout out.)

② Since the above gap may be gradually narrowed owing to the shock during spot-welding, assure the gap to be larger in the initial stage, or timely take care for the gap.

Installation Procedure for Cutter Case

⚠ When installing or detaching cutter case, you must first detach the air hose.

1. Insert cutter into cutter case window.
2. Align the cutter case flange notch to the turning gear notch and insert.

Note A: The cutter case is held by the resilience of the retainer (rubber "O" ring) shown in the diagram. Thus, a slight resistance will be felt when the cutter case is inserted. If the retainer is worn and it becomes easy for the cutter case to come out, the retainer must be replaced.

Note B: Removal: Extrude the cutter case from the opposite side with a finger or using a tool.

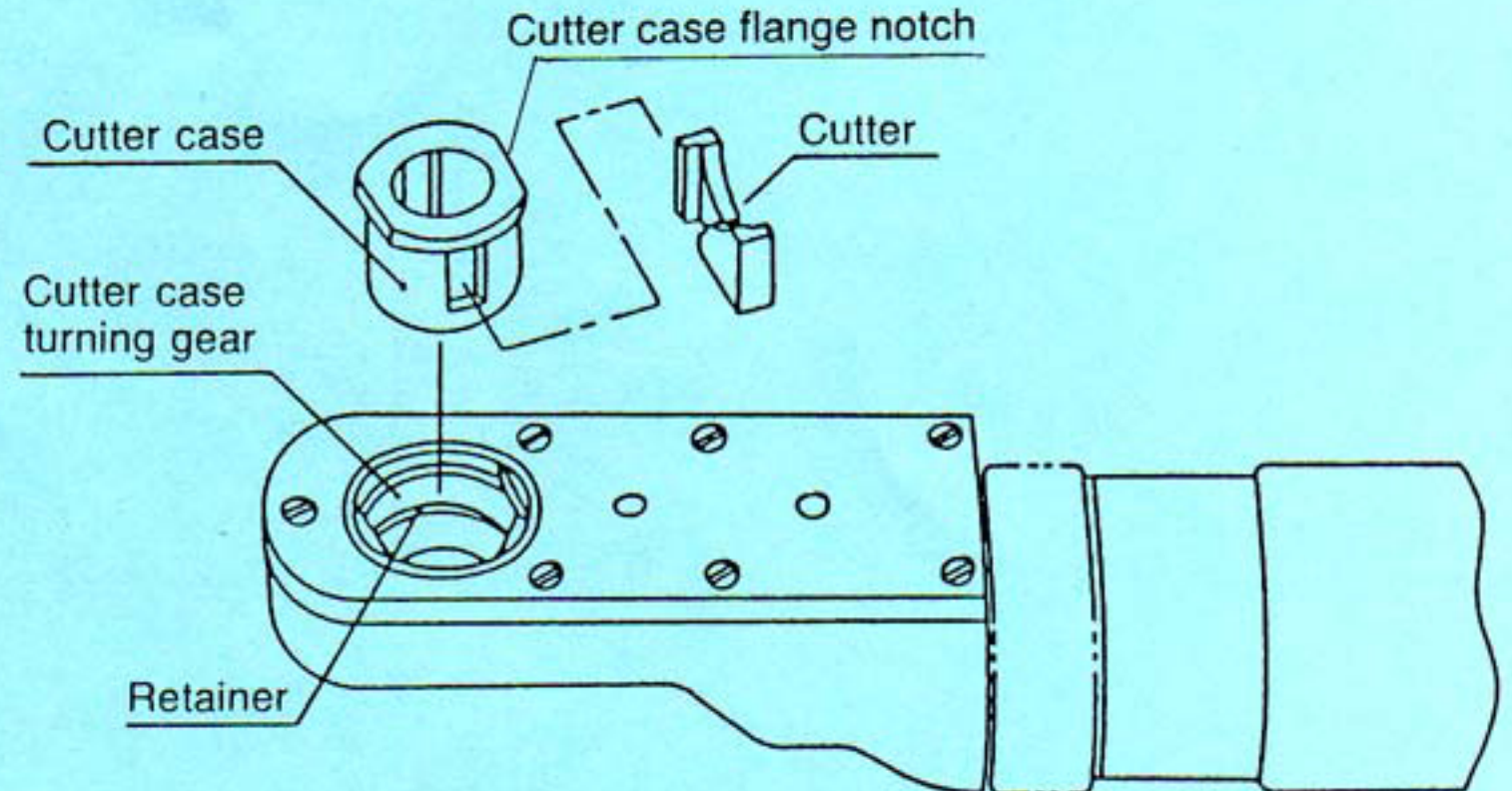

Pneumatic Pressure

⚠ The pneumatic pressure must be set to 6kg/cm². (5-6kg/cm² is the appropriate range.)

Working Procedure (Refer to the illustration fig.1.)

⚠ Refer to the above figure. When beginning work, check to see if the cutter case is firmly retained on the tool side.

1. As shown above, insert the clamp plate under the cap tip.

Note: Previously check whether a clamp plate suitable for the chip size is installed on the tool (The size is stamped. Here, common for ϕ 13 and ϕ 12.).

※ The installing screw has a slight play against the installation hole of the clamp plate. Therefore, when installing the clamp plate, visually align the outer diameter of the cutter case (or the outer diameter of the head bush) on the tool side to the width of the clamp plate, and fasten the clamp plate.

2. Grip the C lever to operate the clamp plate, and insert the chip into the port of the cutter case.

⚠ Do not touch cutter in rotation or the cutter case.

⚠ Never start operating the tool by pressing against the tip while the cutter is stopped.

Note a.: Keep the tool to be square to the axis center of the chip.

Note b.: Since the C lever is linked with the F lever, the tool will start revolving on the way of the chip insertion.

Here, the air valve is a two-step type. It starts slowly revolving at the initial time and revolves at the full speed slightly before the chip comes into contact with the cutter.

3. Gradually increase the gripping force of the C lever, and finally weaken the force for the end.

Note a.: At first, slightly and slowly grip the C lever. When the feeling of the chip cutting becomes stable, strongly grip the lever for cutting. To end the cutting, finally release the force for light cutting.

Note ⚠ Since the chip is abnormally shaped before reconditioning, the resisting force is large against the cutter as to produce a shock (the dragging force tries turning tool.) Therefore, at first, don't grip the C lever strongly.

Note b.: If it is excessively cut, the lives of the chip and cutter will be shortened. Determine the gripping strength and reconditioning time from the experience. (The cutting ability and durability of the cutter depend on the cutter relief angle, chip material, wear during chip reconditioning etc.)

4. Release the C lever, lower the clamp late, and release the chip from the tool (cutter case). Then, pull the clamp plate out of the lower part of the chip.

◇ The tool direction is reversed on the chip that directs downward. Moreover, for the slant direction and others, refer to the above when using the tool.

Shapes of Tip Cutters

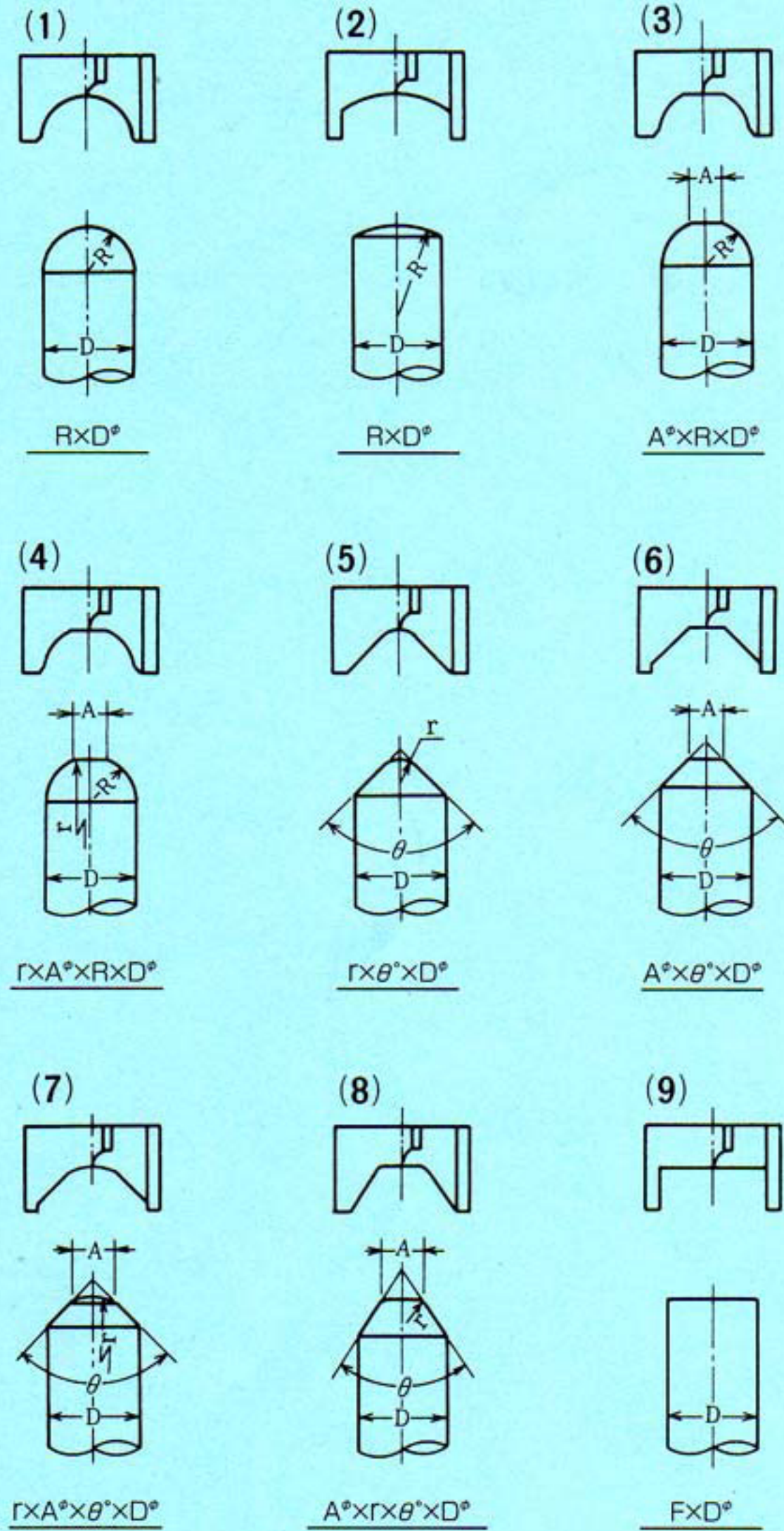

ETD-18F Classification Table.

Cutter No.	TIP shape (Nominal)	Max. diameter that can be repaired (Dφ)	Reserve articles		
<1>	5R	10φ	6R×12φ 6.5R×13φ 8R×16φ		
	6R	12φ			
	6.5R	13φ			
	8R	16φ			
<2>	10R or more (~200R)	18φ	16R×18φ 20R×18φ		
<3>	Aφ×6R	12φ	5φ×6.5R×13φ 6φ×6.5R×13φ 5φ×8R×16φ 6φ×8R×16φ 8φ×8R×16φ		
	Aφ×6.5R	13φ			
	Aφ×8R	16φ			
<4>	rxAφ×6R rxAφ×8R	12φ 16φ	40r×6φ×8R×16φ 40r×8φ×8R×16φ		
<5>	5~6r×60°	13φ			
	3~4r×90°	16φ			
	5r or more×90°	18φ			
<6>	6~9φ×50°	13φ	6φ×60°×13φ 6φ×60°×16φ 6φ×75°×16φ 4φ×90°×18φ 5φ×90°×18φ 6φ×90°×18φ 5φ×120°×18φ 6φ×120°×18φ		
	10φ or more×50°	16φ			
	5~7φ×60° (6φ×60°)	13φ			
	8~9φ×60°	16φ			
	10φ or more×60°	18φ			
	3~4φ×75°	13φ			
	5~6φ×75°	16φ			
	7φ or more×75°	18φ			
	3φ×90°	16φ			
	4φ or more×90°	18φ			
	3φ or more×120°	18φ			
	<7>	rxAφ×θ°		Dφ	
	<8>	Aφ×rxθ°		Dφ	
<9>	F	18φ	F×18φ		

※ETD-25F is also classified the same as above. However, there are no reserve.

Example of Cutter Manufacturing Limitations

(using No.6 above as an example).

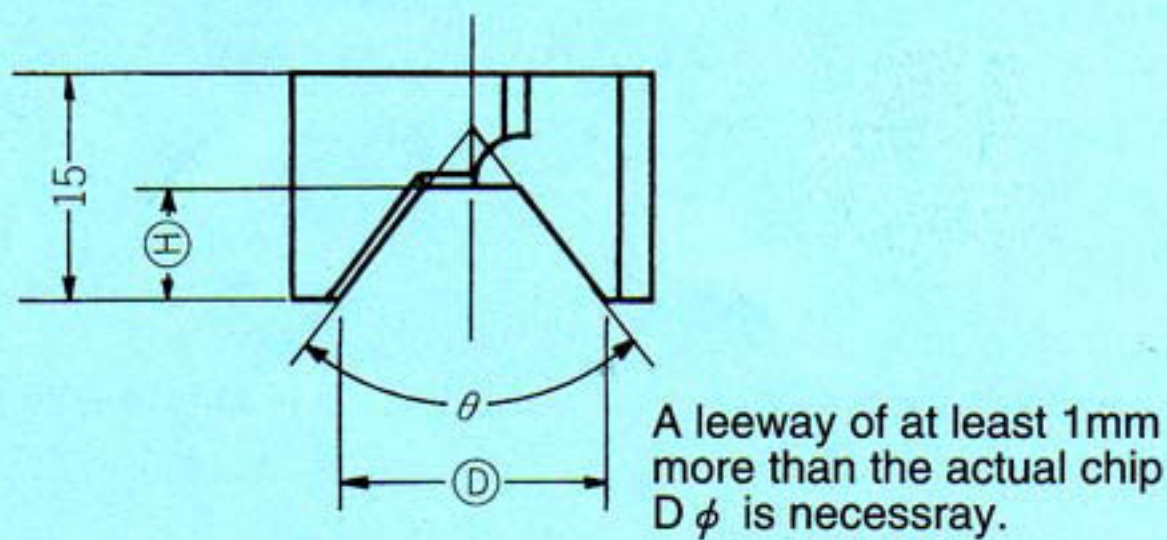

- (1) The cutting edge depth (H) is limited to 7.5mm (which is 1/2 of the total height of 15mm) or less due to strength considerations.
- (2) Should the cutting edge angle θ° on two-blade cutters get too small, chatter will result and the finished shape will be susceptible to breakage. Therefore we limit it to a minimum of 50 degrees.

※ We cannot make items that do not meet conditions (1) and (2).

Cutter Nominal Dimensions and Manufacturing Dimensions

When ordering, please use the above classification table with regards to tip shape when specifying the nominal dimensions for cutters. However, depending on the shape of the tip and as long as the cutting edge depth (H) is not exceeded, we make cutters that can be used up to the maximum diameter of the tip (ETD-0 → 18φ, ETD-1 → 25φ). For example, for an order for a cutter to handle 10R × 16φ tips, the cutter we make will be specified only as 10R. The cutter we supply will in fact be an item for 10R × 18φ. If the tip diameter is 18φ or less, dressing can be performed with this cutter by merely replacing the cutter case with one that matches the tip diameter.

(Ordering example)	Cutter No.	Tip shape (Nominal)	Cutter Supplied
	(6)	6φ × 75° × 12φ	→ 6φ × 75° × 16φ
	(9)	16φ F	→ 18φ F

※For difficult specifications, please send us a print or else an actual cutter.

Cutter Repair

The cutting edges can be repaired two to four times. Please send as many together at once as you can.